



Sniffex Radio Protocol Analyzer

The Sniffex radio protocol analyzer is a versatile PC-based tool for monitoring radio traffic and troubleshooting. The tool decodes transmission on radio channels in real time and presents the results to the user on a PC screen.

By analyzing and interpreting the 8 kbps radio protocol, Sniffex provides a powerful basis for understanding and optimizing the use of the Mobitex radio channel.

A wide range of data can be presented on screen or stored on disk for later processing with other tools. Sniffex is compatible with MIS R4A as used in the NTE, R14E and R14N system software releases.

Primary applications

- Analyzing and measuring traffic volume on a pair of radio channels
- Studying communication characteristics between the mobile and the base station
- Developing and debugging Mobitex applications

Sniffex is available in both desktop and portable versions. The scanners used in the system are controlled by the Sniffex software with respect to frequency selection, etc. The tool operates on the 400, 800 and 900 MHz frequency bands, meaning that it is compatible with virtually all Mobitex networks. Sniffex can also be used together with SA-MTE (Stand Alone Mobitex Test Equipment).

Sniffex

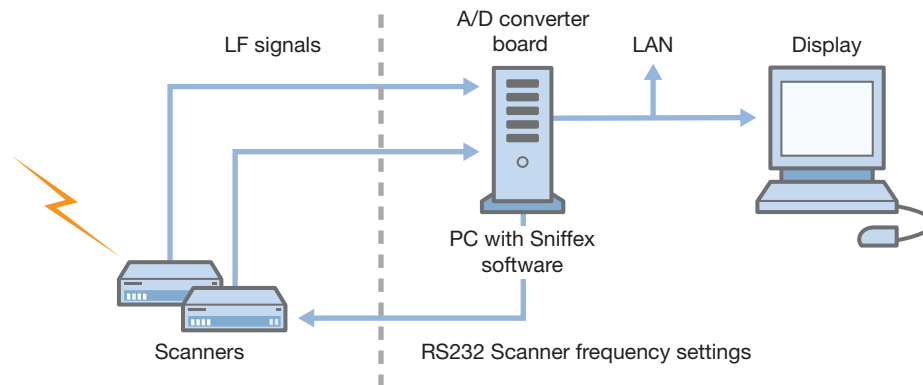

The Sniffex software converts the two streams of 96 kbps digital data, meaning the sampled bits from the radio channels, into data bits, which are then assembled into 8-bit data octets. This data becomes the input to the decoding software, which extracts the Mobitex frames and presents them to the user in mnemonic form in a log window.

There is a wide range of choices for how information will be presented on the Sniffex screen and/or logged to disk. Different presentation formats (e.g.

ASCII or HEX) are also possible. In addition, Sniffex can generate basic statistics for Mobitex signaling, such as counts of the various frame types.

Easy set-up procedure

After installing the A/D card and the Sniffex software on the PC, an easy, step-by-step procedure is followed to define which radio channels to monitor. After completing this procedure, you are ready to monitor and analyze traffic on your Mobitex system.

General description

Delivery of a Sniffex system from Ericsson includes the following:

- Sniffex software and User Manual (both delivered on a CD)
- One A/D sampling card (National Instruments PCI-MIO-16E-1 for the desktop version or DAQCard 6062E for the portable version) plus software
- Two radio scanners (ICOM IC-PCR1000)
- LF, data and power cables (for 12 volt environments)

System requirements

Installation of the Sniffex tool has the following minimum system requirements:

- 10 MB free disk space
- Pentium PC or better
- 500 MHz processor or faster
- 128 MB RAM, minimum
- 12 Volt power supply
- 1 available PCI or PCMCIA slot for the A/D card
- 2 available COM ports for scanner control
- Windows 2000 operating system
- Windows Installer, version 2.0 or later